

Alcoa
Fastening
Systems



INSTRUCTION MANUAL

MODEL 940-220

POWERIG[®] HYDRAULIC UNIT



Makers of Huck[®], Marson[®], Recoil[®]
Brand Fasteners, Tools & Accessories

02-13-2012
HK604





NOTICE:

**This instruction manual applies only to HUCK
Powerig® Model 940-220 with serial number
1191 and above.**



CONTENTS

SAFETY	4
DESCRIPTION	5
SPECIFICATIONS	6
PRINCIPLE OF OPERATION	7
PREPARATION FOR USE	7
OPERATION	8
MAINTENANCE	8
CHECKING AND ADJUSTING PRESSURES	9
SPARE PARTS	10
DIRECTIONAL VALVE OVERLOAD	10
REPLACING PUMP TO MOTOR COUPLING	10
INTERNAL ADJUSTMENT OF PRESSURE SWITCH	10
PUMP OVERHAUL	10
POWERIG ASSEMBLY DRAWING	11
PUMP MOTOR VALVE ASSEMBLY DRAWING	12
ELECTRICAL ENCLOSURE ASSEMBLY DRAWINGS	13-14
PRESSURE SWITCH ASSEMBLY DRAWING	15
TROUBLESHOOTING	16
KITS AND ACCESSORIES	16



SAFETY INSTRUCTIONS

GLOSSARY OF TERMS AND SYMBOLS:



- Product complies with requirements set forth by the relevant European directives.



- **READ MANUAL** prior to using this equipment.



- **EYE PROTECTION IS REQUIRED** while using this equipment.



- **HEARING PROTECTION IS REQUIRED** while using this equipment.



WARNINGS: Must be understood to avoid severe personal injury.



CAUTIONS: show conditions that will damage equipment and or structure.

Notes: are reminders of required procedures.

Bold, Italic type and underlining: emphasizes a specific instruction.

1. A half hour long hands-on training session with qualified personnel is recommended before using Huck equipment.
2. Huck equipment must be maintained in a safe working condition at all times. Tools and hoses should be inspected at the beginning of each shift/day for damage or wear. Any repair should be done by a qualified repairman trained on Huck procedures.
3. Repairman and Operator must read manual prior to using equipment. Warning and Caution stickers/labels supplied with equipment must be understood before connecting equipment to any primary power supply. As applicable, each of the sections in this manual have specific safety and other information.
4. Read MSDS Specifications before servicing the tool. MSDS Specifications are available from the product manufacturer or your Huck representative.
5. When repairing or operating Huck installation equipment, always wear approved eye protection. Where applicable, refer to ANSI Z87.1 - 2003
6. Only genuine Huck parts shall be used for replacements or spares. Use of any other parts can result in tooling damage or personal injury.
7. If a part affixed with warning labels is replaced, or labels are missing or damaged, the end user is responsible for replacement. Refer to assembly drawing and parts list for replacement part number and proper placement.
8. Disconnect primary power source before performing maintenance on Huck equipment or changing Nose Assembly.
9. Tools and hoses should be inspected for leaks at the beginning of each shift/day. If any equipment shows signs of damage, wear, or leakage, do not connect it to the primary power supply.
10. Mounting hardware should be checked at the beginning of each shift/day.
11. Make sure proper power source is used at all times.
12. Release tool trigger if power supply is interrupted.
13. Tools are not to be used in an explosive environment unless specifically designed to do so.
14. Never remove any safety guards or pintail deflectors.
15. Where applicable, ensure deflector or pintail collector is installed and operating prior to use.
16. Never install a fastener in free air. Personal injury from fastener ejecting may occur.
17. Where applicable, always clear spent pintail out of nose assembly before installing the next fastener.
18. There is possibility of forcible ejection of pintails or spent mandrels from front of tool.
19. Check clearance between trigger and work piece to ensure there is no pinch point when tool is activated. Remote triggers are available for hydraulic tooling if pinch point is unavoidable.
20. Unsuitable postures may not allow counteracting of normal expected movement of tool.
21. Do not abuse tool by dropping or using it as a hammer. Never use hydraulic or air lines as a handle or to bend or pry the tool. Reasonable care of installation tools by operators is an important factor in maintaining tool efficiency, eliminating downtime, and in preventing an accident which may cause severe personal injury.
22. Never place hands between nose assembly and work piece. Keep hands clear from front of tool.
23. There is a risk of crushing if tool is cycled without Nose Assembly installed.
24. Tools with ejector rods should never be cycled with out nose assembly installed.
25. When two piece lock bolts are being used always make sure the collar orientation is correct. See fastener data sheet for correct positioning.
26. Tool is only to be used as stated in this manual. Any other use is prohibited.
27. There is a risk of whipping compressed air hose if tool is pneumatic or hydraulic.
28. Release the trigger in case of failure of air supply or hydraulic supply.
29. Use only fluids or lubricants recommended.
30. Disposal instruction: Disassemble and recycle steel, aluminum and plastic parts, and drain and dispose of hydraulic fluid in accordance with local lawful and safe practices.
31. If tool is fixed to a suspension device, ensure that the device is secure prior to operating the tool.



DESCRIPTION

Model 940-220 Powerig Hydraulic Unit is a portable, electrically operated power source designed to operate all Huck hydraulic installation equipment excluding HUCK-SPIN tools.

Please refer to Figure 1. **Bold text** in this section of the manual indicates a part identified in Figure 1. Model 940-220 operates on 220 volt AC, 50-60 Hz, one-phase electrical power. The **power cord** is type SO 600 volt 12/3. The POWERIG Hydraulic Unit requires 15 amp (minimum) circuit with a common wall outlet.

An **electrical enclosure** contains a motor, contactor, a transformer, a relay and a circuit breaker. See also Figure 5.

Hydraulic pressure is developed by a two-stage, gear-piston **pump** driven by a 1-1/8 horsepower universal electric **motor**.

Pressurized fluid is directed by a **four-way directional valve** to either the PULL port or the RETURN port of the installation equipment.

The **four-way directional valve** is operated by a 24 volt AC control circuit. The **high pressure relief valve** controls PULL pressure (maximum pressure of the unit) and is adjustable by the operator.

An internal relief valve is preset at the factory to protect the operator and equipment. The internal relief is not adjustable by the operator.

A **pressure switch** controls RETURN pressure and turns off the POWERIG Hydraulic Unit at the end of an installation cycle.

Pressures are adjustable to match Huck equipment being used. See applicable tool instruction manual for pressure settings for other Huck installation equipment.

Hydraulic fluid is stored in the **reservoir** which also serves as the base. Remove the **filler cap/dipstick** to check fluid level and to add fluid.

Hydraulic quick disconnect couplers are furnished for connecting hoses from installation equipment.

MAIN COMPONENTS

Figure 1

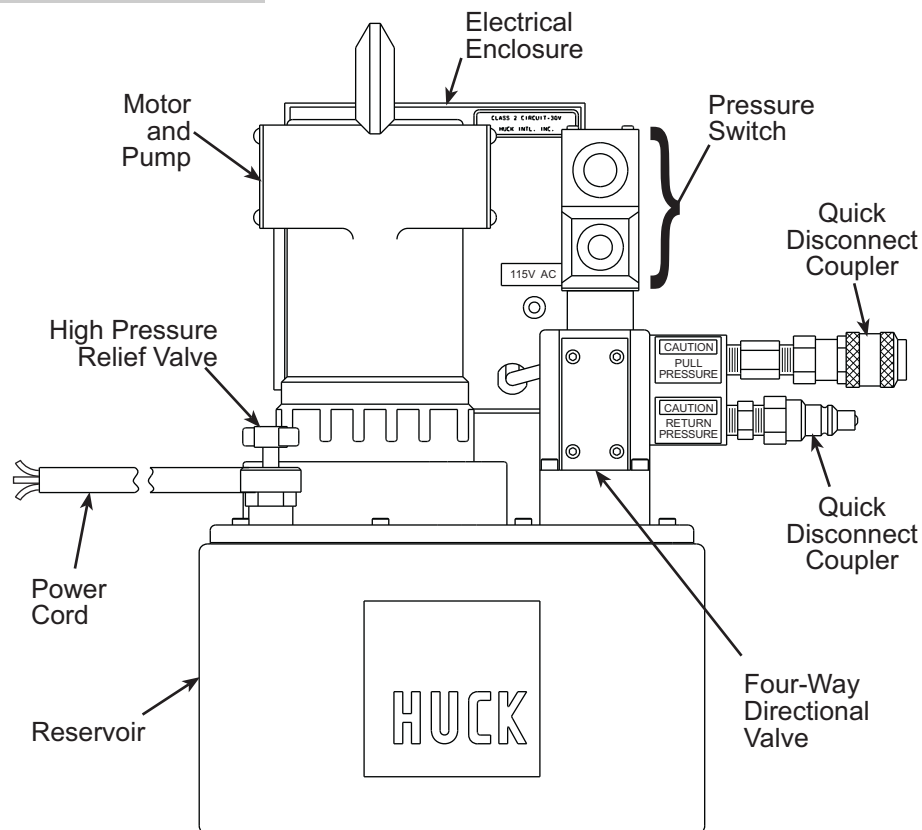



SPECIFICATIONS

Width 16.1 (40.9 cm)

Length 13.9 (35.4 cm)

Height 18.5 (47.0 cm)

Weight (without fluid) 66 lbs. (30 kg)

Reservoir Capacity 2.6 gallons (10 liters)

Electrical System

220 volts, 50/60 hertz, single phase, AC

Control System

Solenoid operated directional valve, 24 volts

Motor 12,000 RPM, 1-1/8 HP, 20 amps nominal

Pump 2-stage gear-piston type, 70 cu.in./min. @5,000 psi out pressure. (Output pressure adjustable to 10,000 psi)

Hydraulic Fluid ATF meeting DEXRON III, DEXRON IV, MERCON, Allison C-4 or equivalent specifications. Fire resistant hydraulic fluid may also be used, and is required to comply with OSHA regulation 1926.302 paragraph (d): "the fluid used in hydraulic power tools shall be fire resistant fluid approved under schedule 30 of the US Bureau of Mines, Department of Interior, and shall retain its operating characteristics at the most extreme temperatures to which it will be exposed."

Pressure Setting as Shipped

RETURN: 2,200-2,400 psi (15,200-16,500 kPa)

PULL: 5,400-5,700 psi (37,200-39,300 kPa)

Min. Operating Temp (ambient) 0° F (-18 ° C)

Max Hydraulic Fluid Temp 150° F (65 ° C)



PRINCIPLE OF OPERATION

Figure 2 shows the electrical schematic diagram of the POWERIG Hydraulic Unit.

Pressure switch (PS) contacts are normally closed. Increasing opens contacts.

When the tool trigger switch is depressed, 24 volts AC is applied between relay terminals CR13 and CR14 activating the relay coil and closing two sets of contacts, CR9-CR5 and CR12-CR8. Closing contacts CR9-CR5 starts the motor. Closing contacts CR12-CR8 activates the solenoid coil of the pilot valve. The pilot valve shifts the directional valve spools. Pressurized fluid is directed to the PULL pressure port of the installation equipment.

When the tool trigger switch is released, the relay contacts open. The solenoid coil is deactivated and the spring return of the pilot valve shifts the directional valve spools. Pressurized fluid is directed to the RETURN pressure port of the installation equipment.

The motor contactor is held closed until the preset RETURN pressure is reached and pressure switch (PS) contacts open. The motor turns off, the pressure drops, and pressure switch returns to the closed (normal) position.

Figure 2

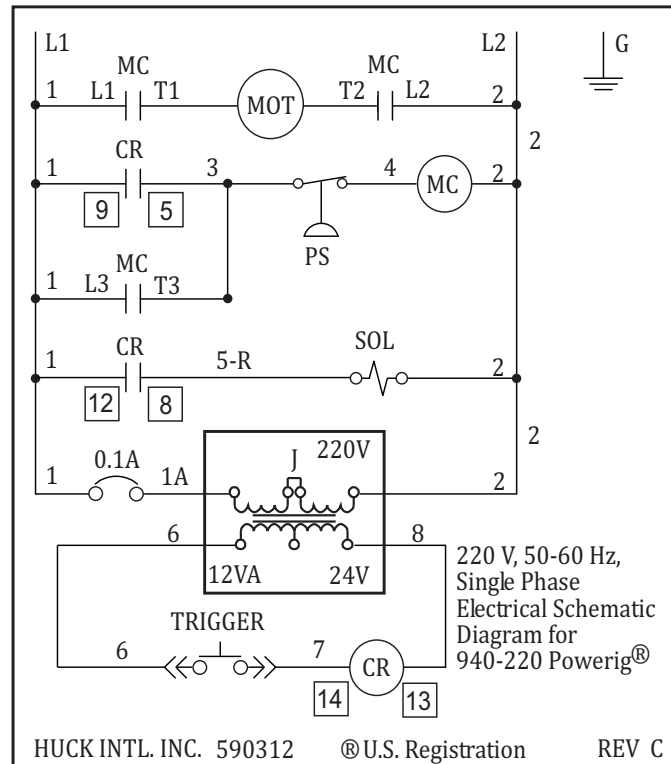

ELECTRICAL SCHEMATIC DIAGRAM

PREPARATION FOR USE

SERVICE

Introduction of foreign material into Hydraulic Unit will result in poor performance and down time for repair. To avoid this, observe the following good practices:

Clean the area around the filler cap before adding hydraulic fluid.

Use a clean funnel with a filter.

Keep quick-disconnect couplers clean by keeping them off the floor. Wipe off quick-disconnect couplers before connecting them.

BEFORE USE

The POWERIG Hydraulic Unit is shipped without hydraulic fluid. Fill the reservoir with hydraulic fluid; approximately 1-1/2 gallons (5.7 liters), until the fluid level is between the grooves of the dipstick.



OPERATION

Each time before using the Powerig Hydraulic Unit:

1. Check the fluid level in the reservoir and add hydraulic fluid as required.
2. Inspect hoses for damage and wear. If hoses show wear that has removed more than the surface texture, they must be replaced.
3. Check the entire system and repair any leaks.
4. Check electrical cord and extension for abrasion and replace as required.

OPERATING TOOLS

Plug the power cord into a grounded wall outlet. If an extension cord is used, it should be UL type SO or STO, 600 volt, 12/3 if 25 feet long and 10/3 if 50 feet long.

Check pressures and adjust as necessary. See the appropriate sections in this manual. **WARNINGS MUST BE UNDERSTOOD BEFORE CHECKING PRESSURES.**

Connect a Huck hydraulic tool to the Powerig Hydraulic Unit using a hose kit.

Be sure that:

1. Hose from PULL PRESSURE on the control panel runs to the port stamped with a letter **P** on the tool.
2. Hose from RETURN PRESSURE on the control panel runs to the port stamped with letter **R** on the tool.

Plug the control cable from the tool into the two-prong socket on the Powerig Hydraulic Unit control panel.

Depress the tool trigger switch and let the the Powerig Hydraulic Unit operate for a few minutes to circulate fluid and remove air from the system.

Attach a nose assembly to the installation equipment. Fasteners may now be installed. Follow instructions in the tool manual.

MAINTENANCE

PREVENTIVE MAINTENANCE

An effective preventive maintenance program includes scheduled inspections to detect and correct minor troubles. Perform the following steps monthly during normal use:

Inspect hydraulic and electrical fittings to be sure they are secure.

Inspect hoses for signs of damage. Replace hoses if abrasion is deeper than the surface texture.

Rotate hoses end-for-end to equalize wear and fatigue.

Inspect during operation to detect any abnormal heating, vibration or leakage.

Inspect hydraulic fluid. If contamination (particles, water, sludge, etc.) is detected, clean the reservoir and replace fluid.

Clean exterior surfaces.

Check supply voltage. Do not operate the POWERIG Hydraulic Unit if the line voltage is more than 5 percent above or below 220 Volts.



CHECKING AND ADJUSTING PRESSURES

CHECKING PRESSURES

WARNINGS MUST BE UNDERSTOOD BEFORE CHECKING PRESSURES. Check pressures before use, before troubleshooting, and after overhauling. See pressures given in specific tool manual. Use T-124833CE gauge to check and adjust pressures.

1. Plug Powerig Hydraulic Unit into a 220 volt, 15 (minimum) amp wall outlet.
2. Plug an auxiliary trigger (optional HUCK part number 113056) into the outlet on the Powerig Hydraulic Unit control panel.
3. Connect T-gauge, Huck part no. T-124833CE, to the hydraulic quick disconnects.
4. Move T-gauge lever to middle position (open).
5. Press and hold the auxiliary trigger to start the Powerig Hydraulic Unit. The motor will start. Hydraulic fluid will be directed to the PULL pressure port of the installation equipment.



CAUTION: This check must be completed quickly, as the hydraulic unit's components should not be subjected to sustained high pressure.

6. Move the T-gauge lever to the PULL position.
7. Read the PULL pressure on the gauge.
8. Move the gauge lever to the "open" position.
9. Release the tool trigger. Hydraulic fluid is directed to the RETURN pressure port of the installation equipment.
10. Slowly move the gauge lever to the RETURN position.
11. Read the maximum pressure on the gauge (just before the unit turns off). This is the RETURN pressure.
12. Disconnect the electrical power.
13. Remove the gauge.

ADJUSTING PRESSURES

NOTE: Use "T" gage T-124833CE to check pressures during adjustment. Set pressures according to the installation equipment manual.

ADJUSTING PULL PRESSURE

NOTE: PULL pressure is the maximum POWERIG® pressure. Do not exceed the pressure rating of the installation equipment. See the installation equipment manual for pressure rating.



WARNING: If recommended maximum pressure is exceeded, violent failure of fastening system may occur. This may cause severe personal injury.

1. Loosen the jam nut of the high pressure relief valve.
2. Turn the adjusting screw clockwise to increase PULL pressure OR counterclockwise to decrease PULL pressure.
3. Tighten the jam nut after PULL pressure has been adjusted.
4. Check PULL pressure. Follow instructions in the appropriate section of this manual.

ADJUSTING RETURN PRESSURE

1. Loosen the jam nut on pressure switch.
2. Turn the adjusting screw clockwise to increase RETURN pressure OR counter-clockwise to decrease RETURN pressure.
3. Tighten the jam nut on pressure switch after return pressure has been adjusted.
4. Check RETURN pressure. Follow instructions in the appropriate section of this manual.



SPARE PARTS

The quantity of spare parts that should be kept on hand varies with the application and number of the Hydraulic Units in service. For directional valve and pilot valve maintenance, Seal Kit, 124100, should be kept on hand at all times. This kit contains O-rings and back-up rings required to service one directional valve and one pilot valve.

Other parts that should be available to the service technician are: Pump to Motor Coupling, Relay, Transformer, Pilot Valve, and Motor Brushes.

DIRECTIONAL VALVE OVERHAUL

If minor overhaul of the directional valve (cleaning and replacing O-rings and back-up rings) is necessary, Seal Kit, 124100, is available. If major overhaul is necessary, return the directional valve to the nearest repair facility shown on the inside of the back cover.

Clean components in mineral spirits. Smear LUBRIPLATE 130AA, or equivalent, on O-rings and mating surfaces to aid assembly and prevent damage to O-rings. LUBRIPLATE is trademarked and manufactured by Fiske Brothers Refining Co. and is available in most localities. A handy tube of LUBRIPLATE 130AA is available from Huck as part number 502723.

REPLACING PUMP TO MOTOR COUPLING

The pump to motor coupling can be replaced by removing four socket cap screws holding the motor housing to the cover plate and lifting the motor to one side. Lift out the original coupling with needle-nose pliers. Drop in the new coupling, align the slots and reassemble motor to cover plate.

INTERNAL ADJUSTMENT OF PRESSURE SWITCH

See Figure 7.

1. Remove the top cover of the switch.
2. Loosen two screws located in the bottom of the switch housing.
3. Place a 0.20-inch-thick shim between the spring retainer and the platen.
4. Loosen the set screw on the spring retainer until it contacts shim.
5. Lock the spring retainer in place with the set screw.
6. Slide the switch mounting bracket toward the switch button until it contacts the platen surface.
7. Secure with two screws located in the middle of the bottom cover.
8. Connect a volt/ohm meter to the electrical cord.
9. Tighten the switch adjustment screw against the switch mounting bracket until the switch button contacts the platen and actuates. The volt/ohm meter will react when the button actuates. A click can be heard.
10. Continue tightening the switch adjustment screw 1/8 of a turn after the switch button actuates.
11. Replace the top cover of the switch.

PUMP OVERHAUL

If pump requires overhaul return it, or the complete unit, to the nearest repair facility shown on the inside of the back cover.

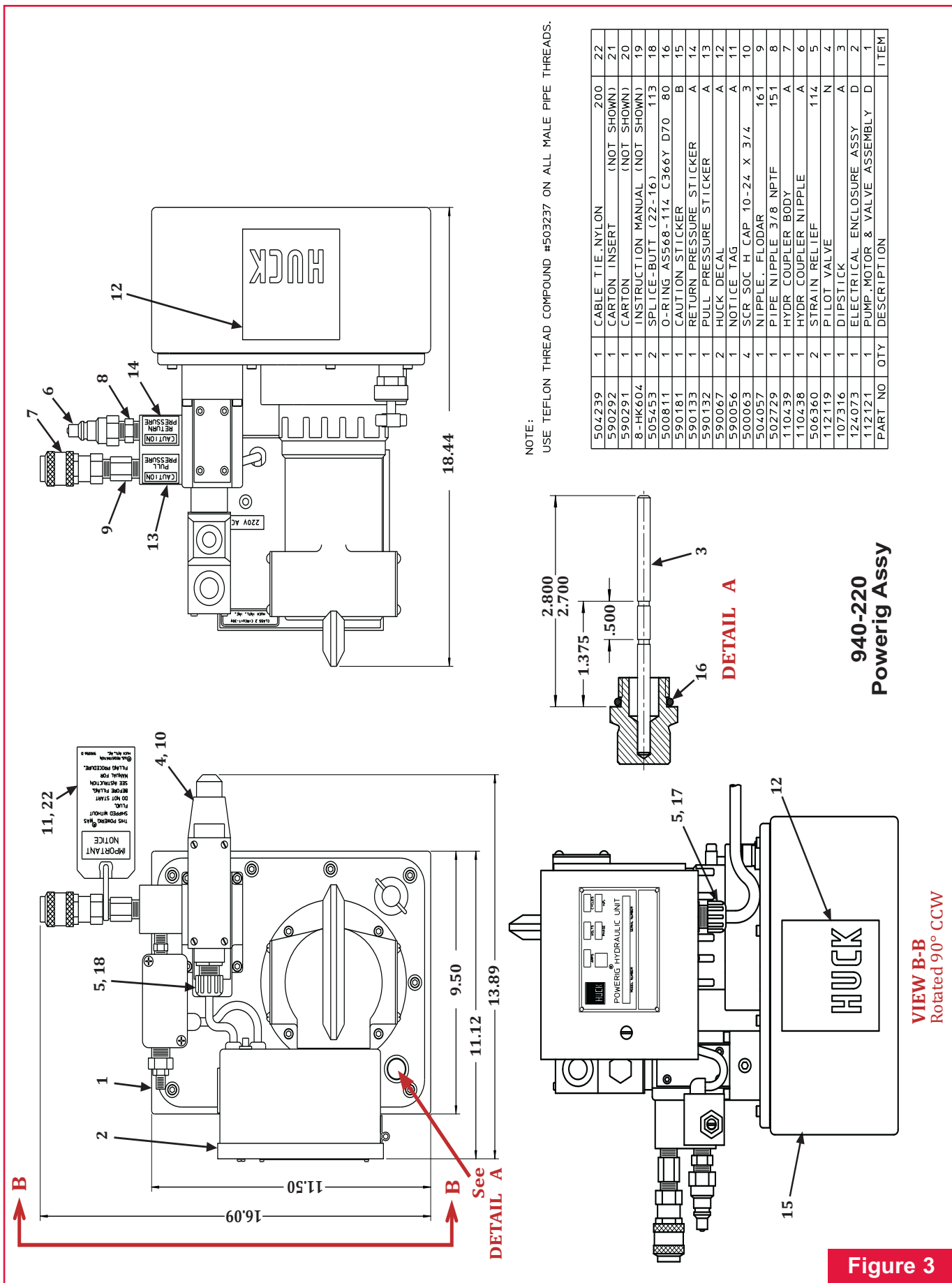
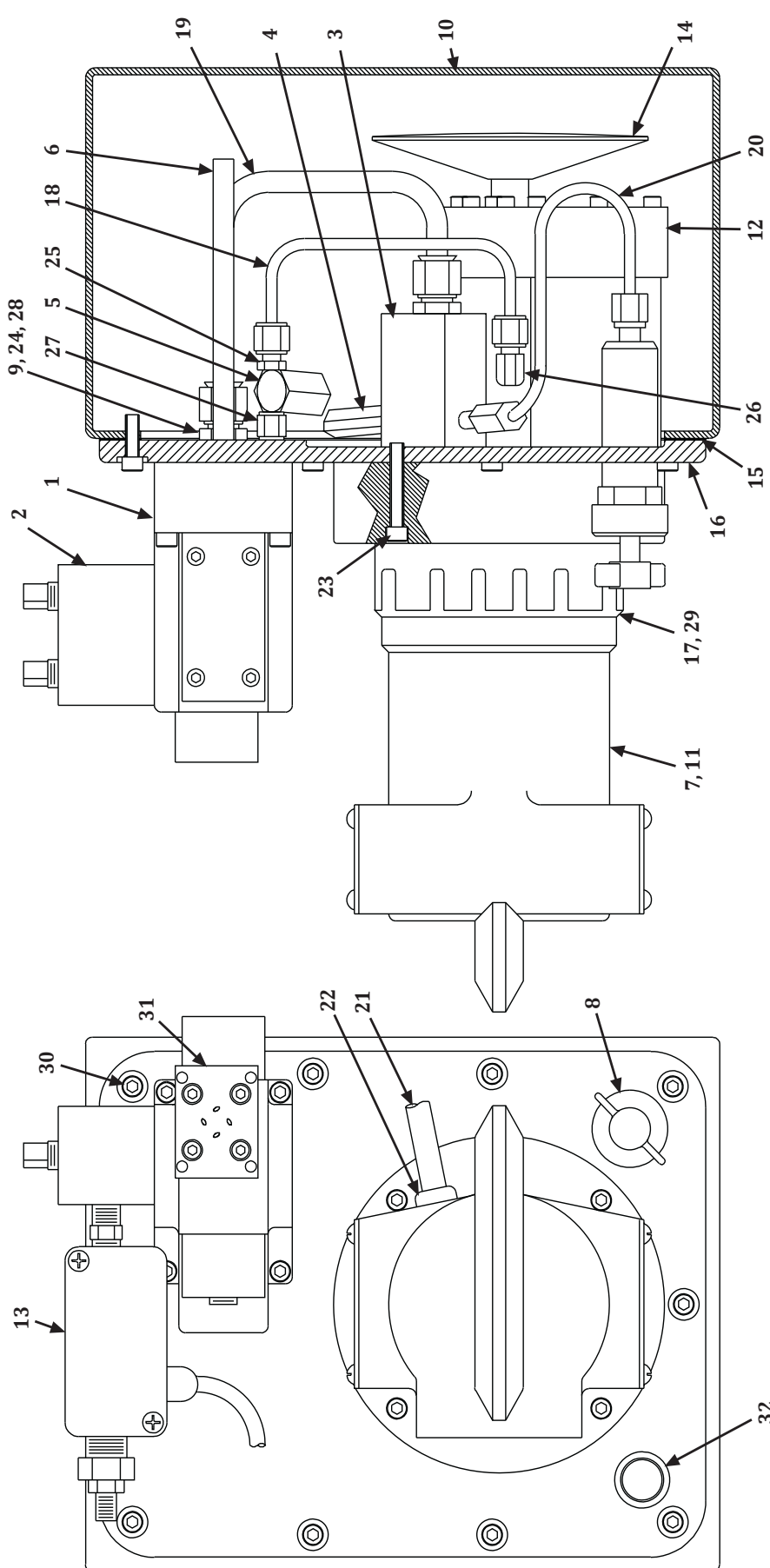

Figure 3



PART NO	QTY	DESCRIPTION	ITEM
107317	1	CAP-FILLER BREATHER	32
112625	1	ADAPTER PLATE,PILOT VALVE	31
500071	10	SCR SOC HD CAP 1/4-20 X 3/4	30
504743	4	SCR RD H MACH 10/24 X 2 ZP	29
504408	1	O-RING AS568-012 CV747 D75	28
504161	1	NIPPLE	27
504158	1	ELBOW	26
504157	2	CONNECTOR	25
503165	1	BACK-UP RING PARBAK 8-012	24
500067	4	SCR SOC H CAP 10-24 X 1-1/2	23
111371	1	STRAIN RELIEF	22
112630	1	POWER CORD FOR 220VAC 940RIG	21
111368	1	RELIEF LINE ASSEMBLY	20
111367	1	PUMP LINE ASSEMBLY	19
111366	1	PILOT LINE ASSEMBLY	18
111365	1	MOTOR BASE	17

PART NO	QTY	DESCRIPTION	ITEM
111364	1	COVER PLATE	16
111357	1	COVER PLATE GASKET	15
111355	1	FILTER ASSEMBLY	14
115753	1	PRESSURE SWITCH ASSEMBLY	13
111347	1	PUMP ASSEMBLY	12
112117	1	MOTOR 1-1/8 HP 220V	11
111189	1	RESERVOIR	10
107217	1	ADAPTER UNION	9
106397	1	EXTERNAL RELIEF VALVE	8
103918	1	PUMP MOTOR COUPLING	7
103904	1	RETURN LINE	6
103903	1	ACCUMULATOR	5
103901	1	RELIEF VALVE	4
103900	1	CHECK VALVE	3
103599	1	MANIFOLD	2
103596	1	DIRECTIONAL VALVE	1

NOTES.

- THIS ASSEMBLY IS PURCHASED COMPLETE. THE BILL OF MATERIAL LISTED IS FOR REFERENCE AND REPLACEMENT PART PURPOSES ONLY.

112121
Pump Motor Valve Assy

Figure 4

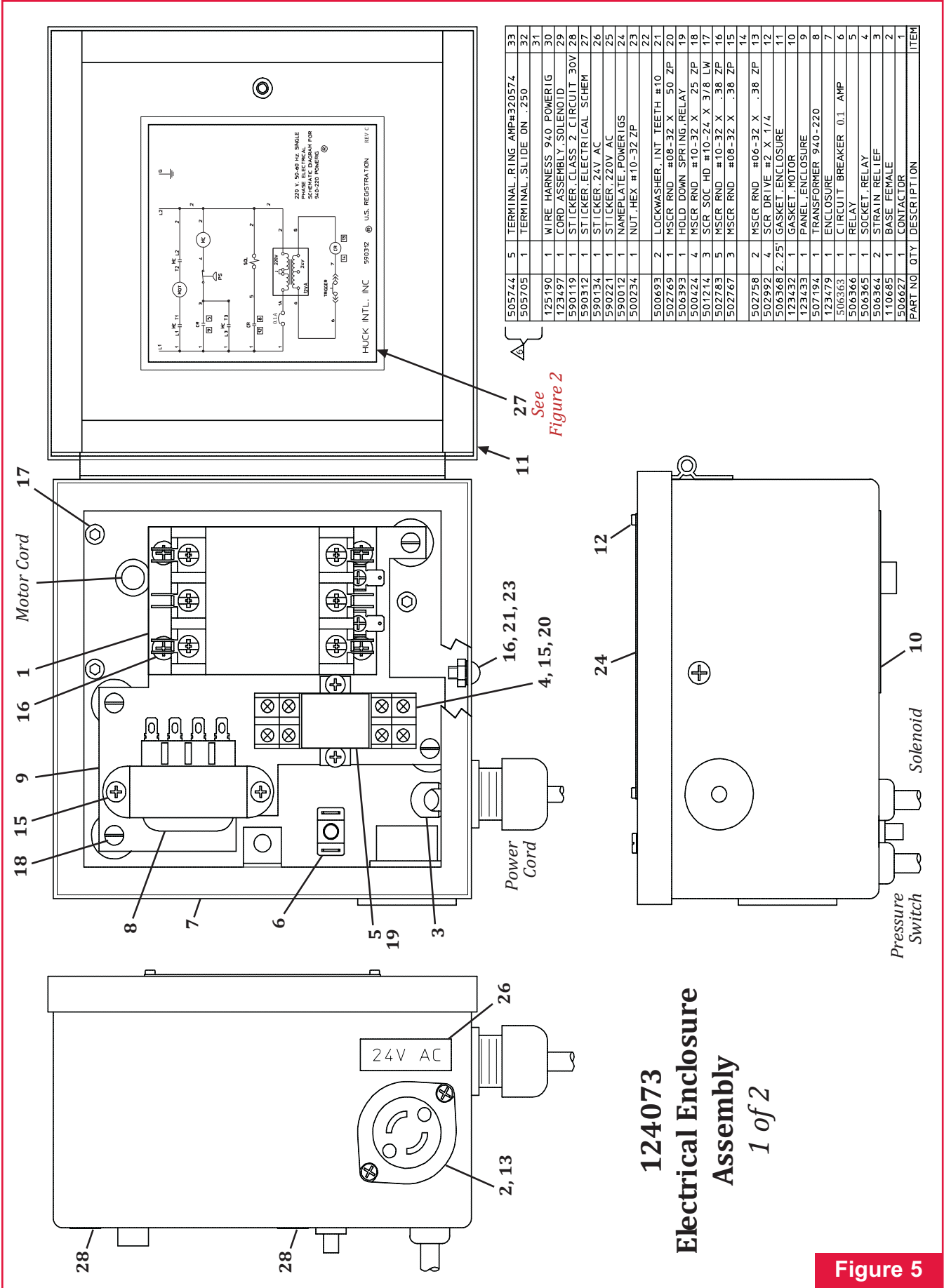
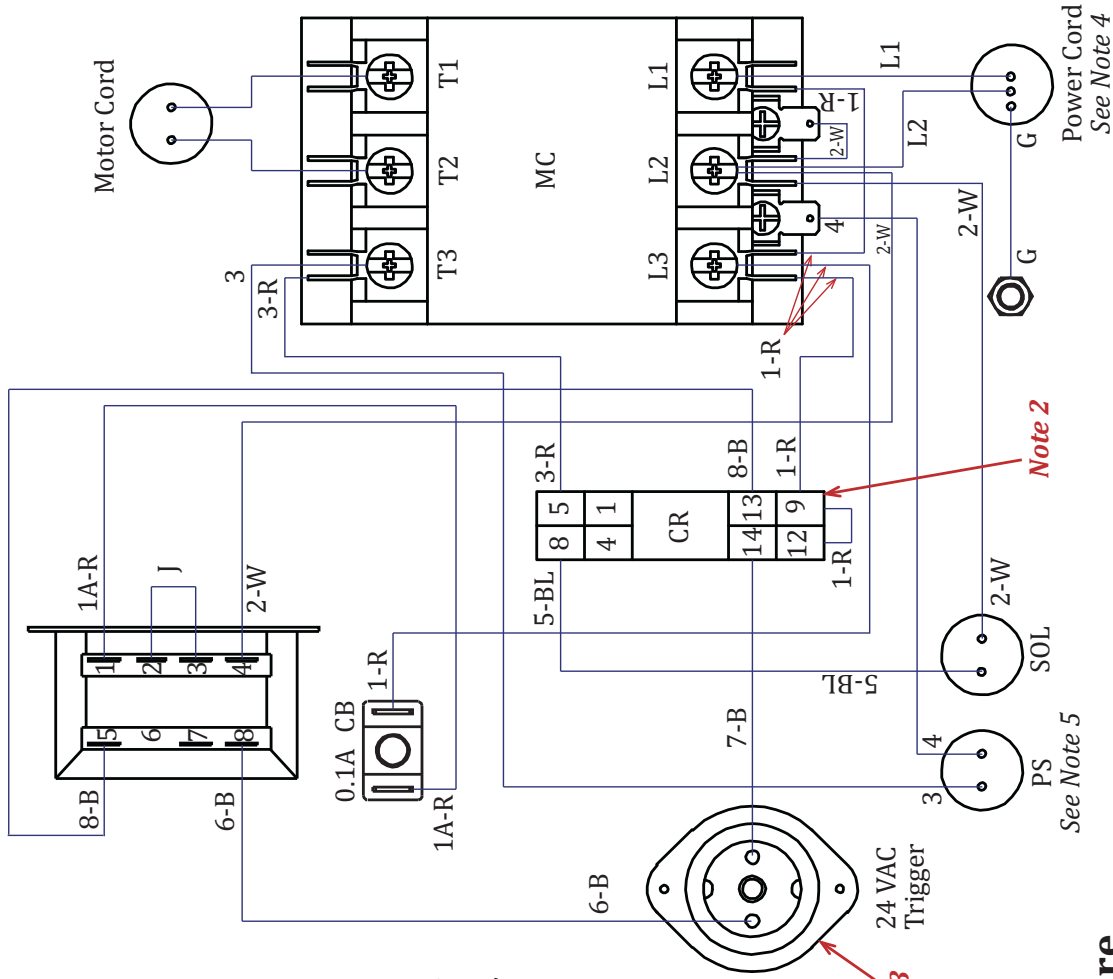

Figure 5



Notes:

1. Wire Label Code:

XX - XX	R = Red
	W = White
	B = Blue
	BL = Black

Indicates alphanumeric label to appear at both ends of the conductor.
2. Connections made to 506365 Socket Relay, strip end of wire 0.30 inches.
3. Connections made to 110685 Female Base, strip end of wire 0.50 inches.
4. Wire color code for Power Cord:

L1=	Light Blue or Black
L2=	Brown or White
G	Green/Yellow or Green
5. Wire color code for Pressure Switch:

3	= Light Blue or Black
4	= Brown or White

TERMINAL	WIRE NUMBER LOCATION
505705	Pressure Switch 4
505744	Pressure Switch 3, Motor Wires, and Power Cord L1 & L2

124073
Electrical Enclosure
Assembly
 2 of 2

Figure 6

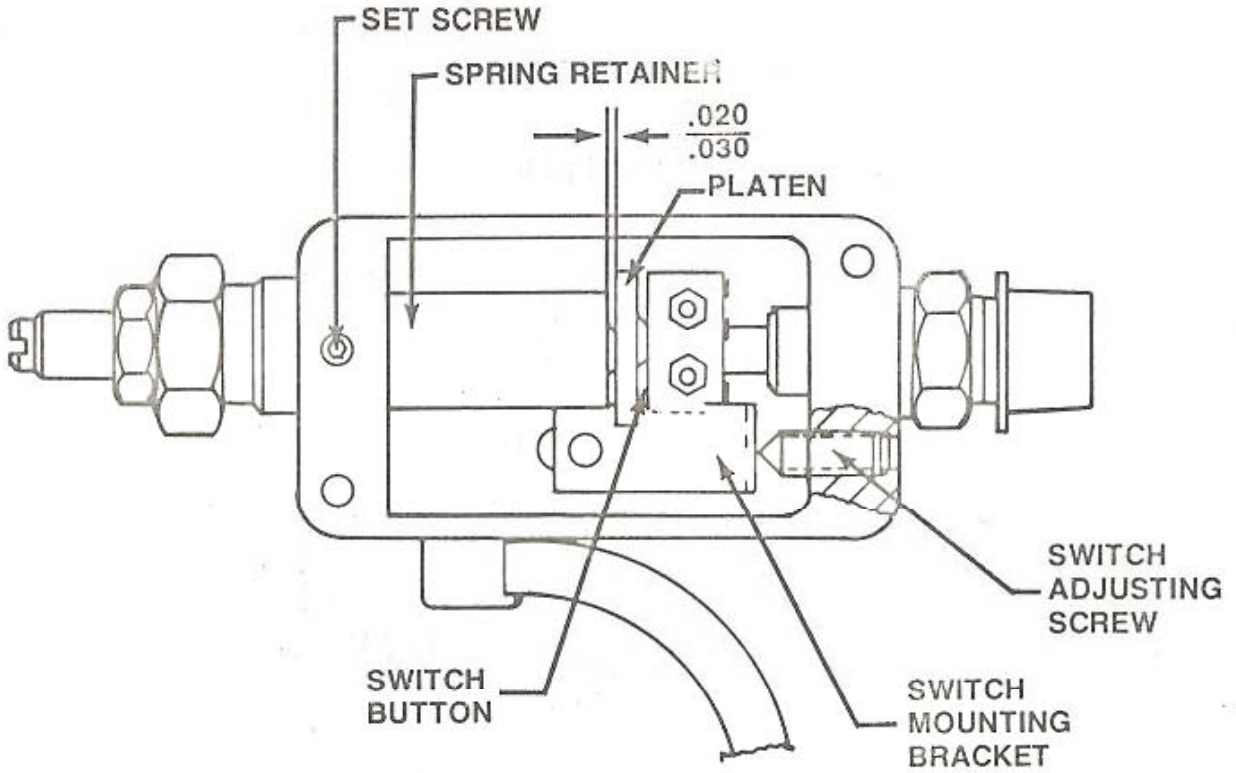

PRESSURE SWITCH DETAIL



TROUBLESHOOTING

Always check the simplest possible cause of malfunction first. For example, blown fuse, tripped circuit breaker, defective switch or control cord. Eliminate each possible cause until the defective circuit or part is located. Where possible, substitute known good parts for suspected bad parts. A qualified electrician should check out the electrical system. Use the guide below as an aid in locating trouble and correcting it.

1. Motor fails to start when trigger is depressed.

- Loose or faulty control cord or connectors.
- Power source not properly fused.
- Defective tool switch.
- Loose wire(s).
- Defective relay.
- Incorrect power source.
- Defective motor contactor.
- Defective transformer.

2. Motor runs, but tool will not reciprocate.

- Hoses not coupled properly.
- Hydraulic fluid viscosity not proper or level is too low.
- Defective pilot valve solenoid or coil.
- Unloading valve missing in tool.
- Bind in tool or nose assembly.
- Defective directional valve
- Pump to motor coupling damaged.

3. Pintail fastener fails to break off.

- PULL pressure set too low.
- Worn or defective hose couplers.
- Hydraulic fluid viscosity not proper or level is too low.
- Hydraulic fluid overheated.
- Worn or defective directional valve.
- Internal relief valve set too low or defective.
- Worn or defective pump.

4. Tool will not return when switch is released.

(Tool will not push nose assembly off swaged fastener.)

- RETURN pressure set too low.
- Hoses not coupled properly.
- Worn or defective solenoid.
- Worn or defective pilot valve.

5. Motor fails to shut off when installation cycle is completed.

- RETURN pressure is set too high.
- Hydraulic fluid viscosity not proper or level is low.
- Hydraulic fluid overheated.
- Defective limit switch in pressure switch assembly.

6. Pump making noise throughout entire cycle.

- Pump is cavitating. Fluid level may be low or fluid viscosity is too heavy.
- Strainer is dirty and clogged.

7. Tool will not return when switch is released.

(Tool will not push nose assembly off swaged fastener.)

- Pump is cavitating. Fluid level may be low or fluid viscosity is too heavy.
- Strainer is dirty and clogged.
- Worn or defective directional valve.
- Worn or damaged pump.
- Worn or defective hydraulic couplers.

KITS AND ACCESSORIES

Auxiliary Switch and Control Cord 113056

An auxiliary switch is available for use when checking and adjusting pressures and when troubleshooting.

Gauge T-124833CE

A "T" gauge is available for use when checking and adjusting pressures, and troubleshooting.

Hose and Control Cord Kits of various lengths

Please contact your HUCK representative.

Directional Valve Seal Kit 124100

Includes seals necessary to service Directional Valve 103596.

Rig Transport Dolly 116685

Heavy duty steel dolly for easy movement of rig throughout the work area.

LIMITED WARRANTIES

TOOLING WARRANTY:

Huck warrants that tooling and other items (excluding fasteners, and hereinafter referred as "other items") manufactured by Huck shall be free from defects in workmanship and materials for a period of ninety (90) days from the date of original purchase.

WARRANTY ON "NON STANDARD OR CUSTOM MANUFACTURED PRODUCTS":

With regard to non-standard products or custom manufactured products to customer's specifications, Huck warrants for a period of ninety (90) days from the date of purchase that such products shall meet Buyer's specifications, be free of defects in workmanship and materials. Such warranty shall not be effective with respect to non-standard or custom products manufactured using buyer-supplied molds, material, tooling and fixtures that are not in good condition or repair and suitable for their intended purpose.

THERE ARE NO WARRANTIES WHICH EXTEND BEYOND THE DESCRIPTION ON THE FACE HEREOF. HUCK MAKES NO OTHER WARRANTIES AND EXPRESSLY DISCLAIMS ANY OTHER WARRANTIES, INCLUDING IMPLIED WARRANTIES AS TO MERCHANTABILITY OR AS TO THE FITNESS OF THE TOOLING, OTHER ITEMS, NONSTANDARD OR CUSTOM MANUFACTURED PRODUCTS FOR ANY PARTICULAR PURPOSE AND HUCK SHALL NOT BE LIABLE FOR ANY LOSS OR DAMAGE, DIRECTLY OR INDIRECTLY, ARISING FROM THE USE OF SUCH TOOLING, OTHER ITEMS, NONSTANDARD OR CUSTOM MANUFACTURED PRODUCTS OR BREACH OF WARRANTY OR FOR ANY CLAIM FOR INCIDENTAL OR CONSEQUENTIAL DAMAGES.

Huck's sole liability and Buyer's exclusive remedy for any breach of warranty shall be limited, at Huck's option, to replacement or repair, at FOB Huck's plant, of Huck manufactured tooling, other items, nonstandard or custom products found to be defective in specifications, workmanship and materials not otherwise the direct or indirect cause of Buyer supplied molds, material, tooling or fixtures. Buyer shall give Huck written notice of claims for defects within the ninety (90) day warranty period for tooling, other items, nonstandard or custom products described above and Huck shall inspect products for which such claim is made.

TOOLING, PART(S) AND OTHER ITEMS NOT MANUFACTURED BY HUCK:

HUCK MAKES NO WARRANTY WITH RESPECT TO THE TOOLING, PART(S) OR OTHER ITEMS

MANUFACTURED BY THIRD PARTIES. HUCK EXPRESSLY DISCLAIMS ANY WARRANTY EXPRESSED OR IMPLIED, AS TO THE CONDITION, DESIGN, OPERATION, MERCHANTABILITY OR FITNESS FOR USE OF ANY TOOL, PART(S), OR OTHER ITEMS THEREOF NOT MANUFACTURED BY HUCK. HUCK SHALL NOT BE LIABLE FOR ANY LOSS OR DAMAGE, DIRECTLY OR INDIRECTLY, ARISING FROM THE USE OF SUCH TOOLING, PART(S) OR OTHER ITEMS OR BREACH OF WARRANTY OR FOR ANY CLAIM FOR INCIDENTAL OR CONSEQUENTIAL DAMAGES.

The only warranties made with respect to such tool, part(s) or other items thereof are those made by the manufacturer thereof and Huck agrees to cooperate with Buyer in enforcing such warranties when such action is necessary.

Huck shall not be liable for any loss or damage resulting from delays or nonfulfillment of orders owing to strikes, fires, accidents, transportation companies or for any reason or reasons beyond the control of the Huck or its suppliers.

HUCK INSTALLATION EQUIPMENT:

Huck International, Inc. reserves the right to make changes in specifications and design and to discontinue models without notice.

Huck Installation Equipment should be serviced by trained service technicians only.

Always give the Serial Number of the equipment when corresponding or ordering service parts.

Complete repair facilities are maintained by Huck International, Inc. Please contact one of the offices listed below.

Eastern

One Corporate Drive Kingston, New York 12401-0250
Telephone (845) 331-7300 FAX (845) 334-7333

Outside USA and Canada

Contact your nearest Huck International Office, see back cover.

In addition to the above repair facilities, there are Authorized Tool Service Centers (ATSC's) located throughout the United States. These service centers offer repair services, spare parts, Service Parts Kits, Service Tools Kits and Nose Assemblies. Please contact your Huck Representative or the nearest Huck office listed on the back cover for the ATSC in your area.



For the Long Haul™

A Global Organization

Alcoa Fastening Systems (AFS) maintains company offices throughout the United States and Canada, with subsidiary offices in many other countries. Authorized AFS distributors are also located in many of the world's

Industrial and Aerospace centers, where they provide a ready source of AFS fasteners, installation tools, tool parts, and application assistance.

Alcoa Fastening Systems world-wide locations:

Americas

Alcoa Fastening Systems
Aerospace Products
Tucson Operations
3724 East Columbia
Tucson, AZ 85714
800-234-4825
520-747-9898
FAX: 520-748-2142

Alcoa Fastening Systems
Aerospace Products
Carson Operations
PO Box 5268
900 Watson Center Rd.
Carson, CA 90749
800-421-1459
310-830-8200
FAX: 310-830-1436

Alcoa Fastening Systems
Industrial Products
Waco Operations
PO Box 8117
8001 Imperial Drive
Waco, TX 76714-8117
800-388-4825
254-776-2000
FAX: 254-751-5259

Alcoa Fastening Systems
Industrial Products
Kingston Operations
1 Corporate Drive
Kingston, NY 12401
800-278-4825
845-331-7300
FAX: 845-334-7333

Alcoa Fastening Systems
Industrial Products
Latin America Operations
Avenida Parque Lira. 79-402
Tacubaya Mexico, D.F.
C.P. 11850
FAX: 525-515-1776
TELEX: 1173530 LUKSME

Far East

Alcoa Fastening Systems
Industrial Products
Australia Operations
14 Viewtech Place
Rowville, Victoria
Australia 3178
03-764-5500
Toll Free: 008-335-030
FAX: 03-764-5510

Europe

Alcoa Fastening Systems
Industrial Products
United Kingdom Operations
Unit C, Stafford Park 7
Telford, Shropshire
England TF3 3BQ
01952-290011
FAX: 0952-290459

Alcoa Fastening Systems
Aerospace Products
France Operations
Clos D'Asseville
BP4
95450 Us Par Vigny
France
33-1-30-27-9500
FAX: 33-1-34-66-0600



For The Long Haul, The Future of Fastening Technology, The Future of Assembly Technology, The Future of Tooling Technology, and Tools of Productivity are service marks of Huck International. Huck provides technical assistance regarding the use and application of Huck fasteners and tooling.

NOTICE: The information contained in this publication is only for general guidance with regard to properties of the products shown and/or the

means for selecting such products, and is not intended to create any warranty, express, implied, or statutory; all warranties are contained only in Huck's written quotations, acknowledgements, and/or purchase orders. It is recommended that the user secure specific, up-to-date data and information regarding each application and/or use of such products.

HWB898 1003-5M

Alcoa Fastening Systems



One Great ConnectionSM